

# TELECOM/ PARCEL DELIVERY

Our Telecommunications packages have storage for the various equipment you need for cable and telephone services. Connectors and other small items have a home in parts drawers, while monitors can be locked securely away in larger cabinets. Open shelving provides convenient access for parcel delivery needs. Remember, all of WEATHER GUARD® Van Solutions packages are customizable with an extensive list of accessory components that can be mixed and matched to suit your needs.

	Model	Description	Quantity
1	86510-3-01	Window Bulkhead	1
2	8875	Hard Hat Bracket	1
3	8873-3-01	Extension Cord Brackets (3)	1
4	9400-3-01	42" x 14" Welded Shelf	1
5	8401-3-01	Dividers	1
6	9452-3-01	51" x 14" Welded Shelf	1
7	8401-3-01	Dividers	2
8	8918-3	18 Drawer Parts Cabinet	1
9	8503-3-01	Shelf Door	1
10	8141-3-01	42" Wheel Well Cabinet	1
11	8316-3-01	CATV Box	2
12	8361-3	Literature Holder	1

Package Ship Wt. 472

## FULL-SIZE VAN PACKAGE # 600-3007

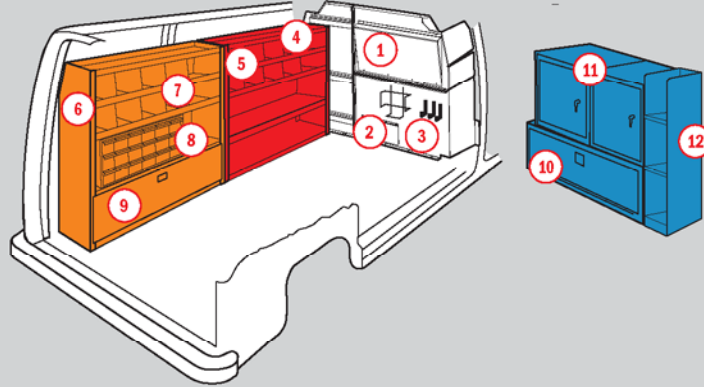

	Model	Description	Quantity
1	85500 3 02	Screen Bulkhead	1
2	85555-3-01	Swing Door Hinge Kit	1
3	8383-3-01	42" x 18" Shelf Unit	1
4	8385-3-01	69" x 18" Shelf Unit	1
5	8477-3-01	60" x 14" Tapered Shelf Unit	1

Package Ship Wt. 458

## SPRINTER VAN PACKAGE # 600-3045

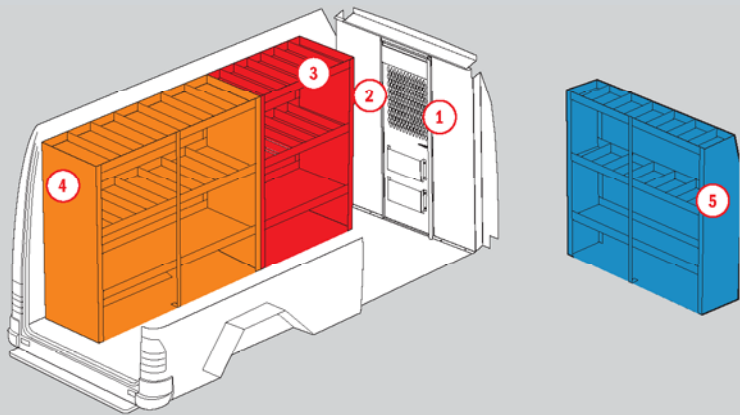

	Model	Description	Quantity
1	8384-3-01	51" x 18" Shelf Unit	1
2	8803-3-01	Retainer Lip	1
3	8384-3-01	51" x 18" Shelf Unit	1
4	8803-3-01	Retainer Lip	1
5	8394-3-01	51" x 24" Shelf Unit	1
6	8803-3-01	Retainer Lip	1
7	8394-3-01	51" x 24" Shelf Unit	1
8	8803-3-01	Retainer Lip	1
9	8875	Hard Hat Bracket	1

Package Ship Wt. 572

## CUBE VAN PACKAGE # 600-3025

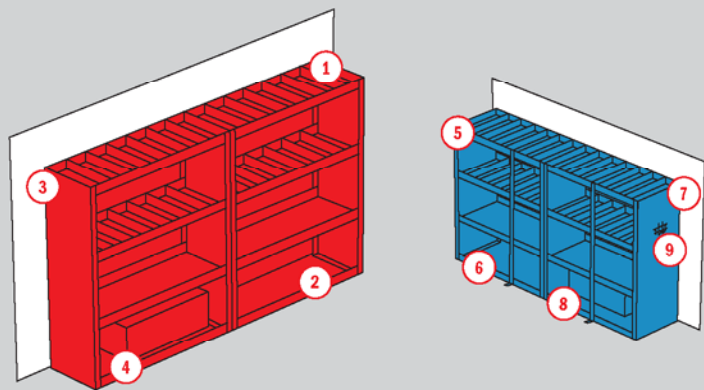

### YOU MAY ALSO NEED:



**QUICK CLAMP RACK** Page 28



**WIRE SPOOL RACK** Page 18



**CABLE TV BOXES** Page 17